

**THE B600 PRESENTS ITSELF ----- page 2**

**CONTROL AND DISPLAY ----- page 3**

**MICROPHONES ----- page 4**

**SYSTEM CONFIGURATION ----- page 5**

**SYSTEM CONFIGURATION ----- page 6**

**EXPLANATION OF TEST PARAMETERS ----- page 7**

**DISPLAY OF WATCH SIGNAL ----- page 8**

**AUTO CALCULATION OF AMPLITUDE ----- page 9**

**MEASURING WINDOW ----- page 10**

**TESTING CLOCKS ----- page 11**

**TESTING QUARTZ WATCHES ----- page 12**

**TESTING QUARTZ WATCHES ----- page 13**

**TESTING QUARTZ WATCHES ----- page 14**

**CALIBRATION AND ADJUSTMENTS ----- page 15**

**TECHNICAL DATAS----- page 16**

**Front-view**

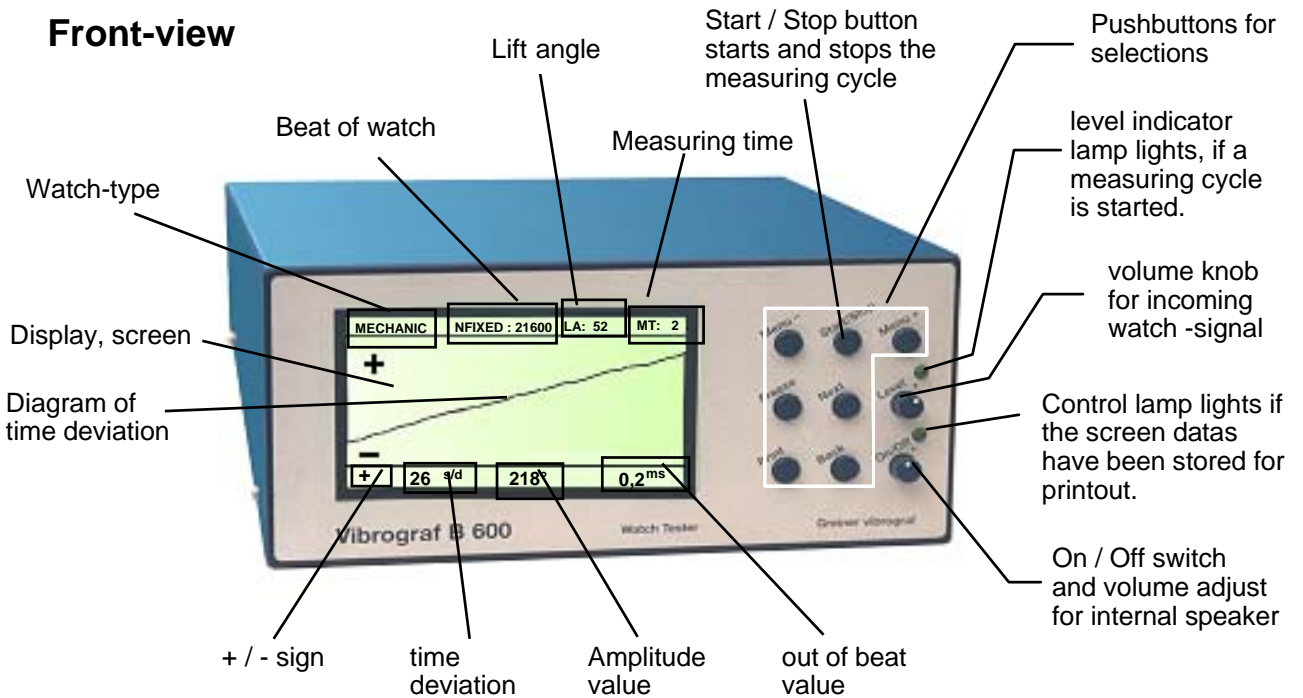

**Rear view**

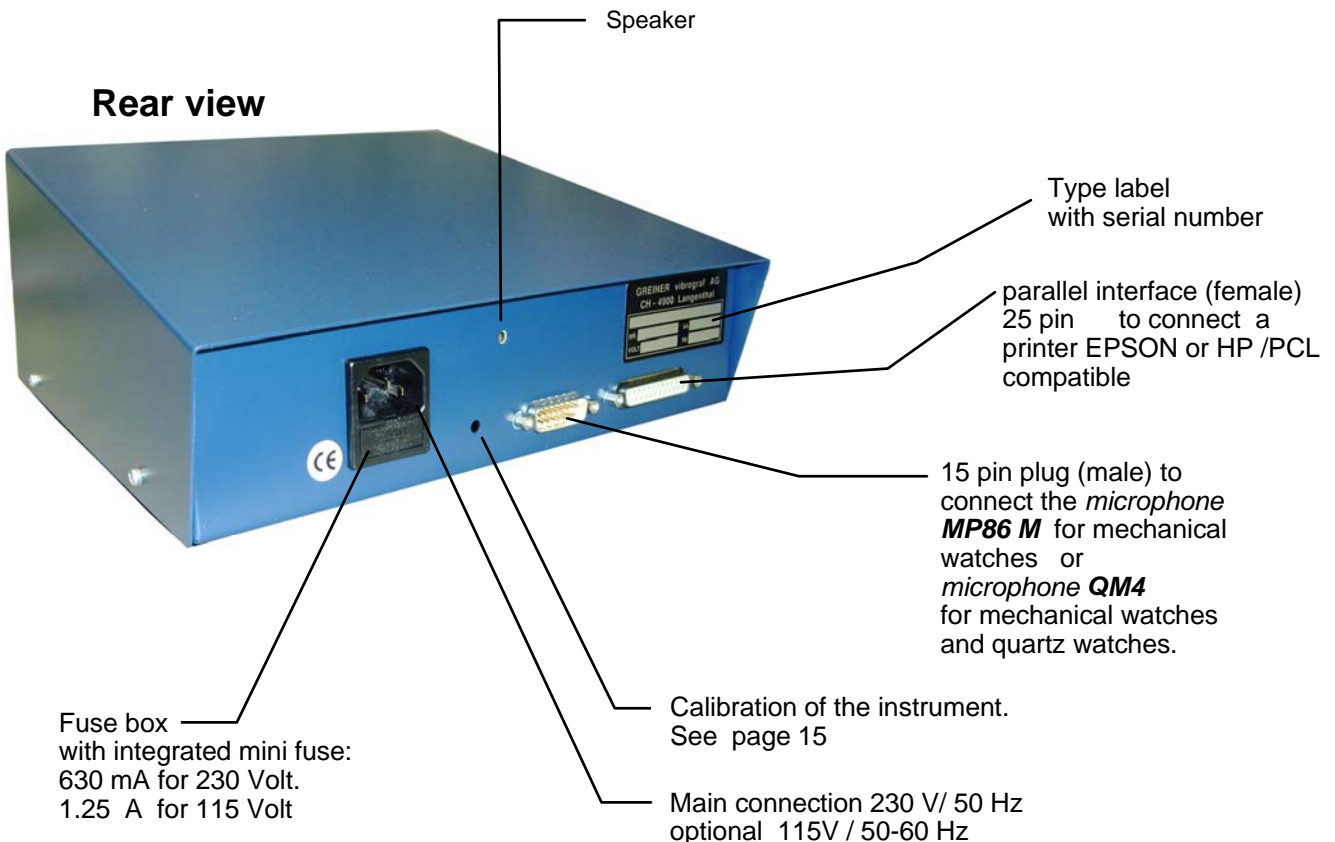

**CONTROL BUTTONS**

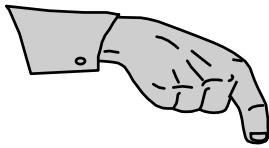

Start / Stop button starts and stops the measuring cycle

1. Selects the preceding MENU - point.  
2. Decreases of a value.

1. Stores the display datas for printout.  
2. Switches to the double beat.

Goas to the next MENU - point.

1. Starts the printout.  
2. Switches to the single beat..  
3. Shows the menu for system changemnts.

Goas to the preceding MENU - point.

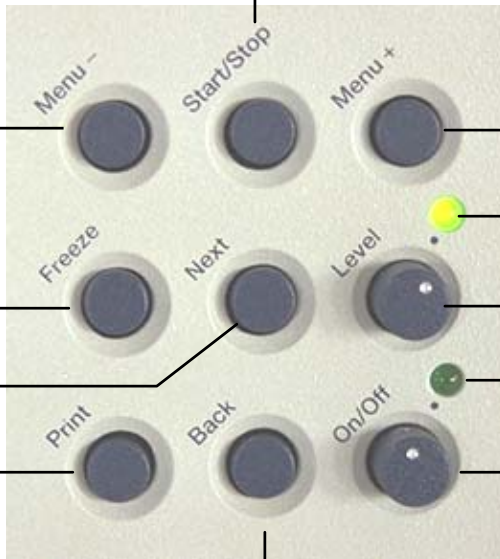

Selects the next MENU - point. -or- increases the value.

level indicator lamp lights, if a measuring cycle is started.

volume knob for incoming watch -signal

Control lamp lights if the screen datas have been stored for printout.

On / Off switch and volume adjust for internal speaker

**Display, screen**

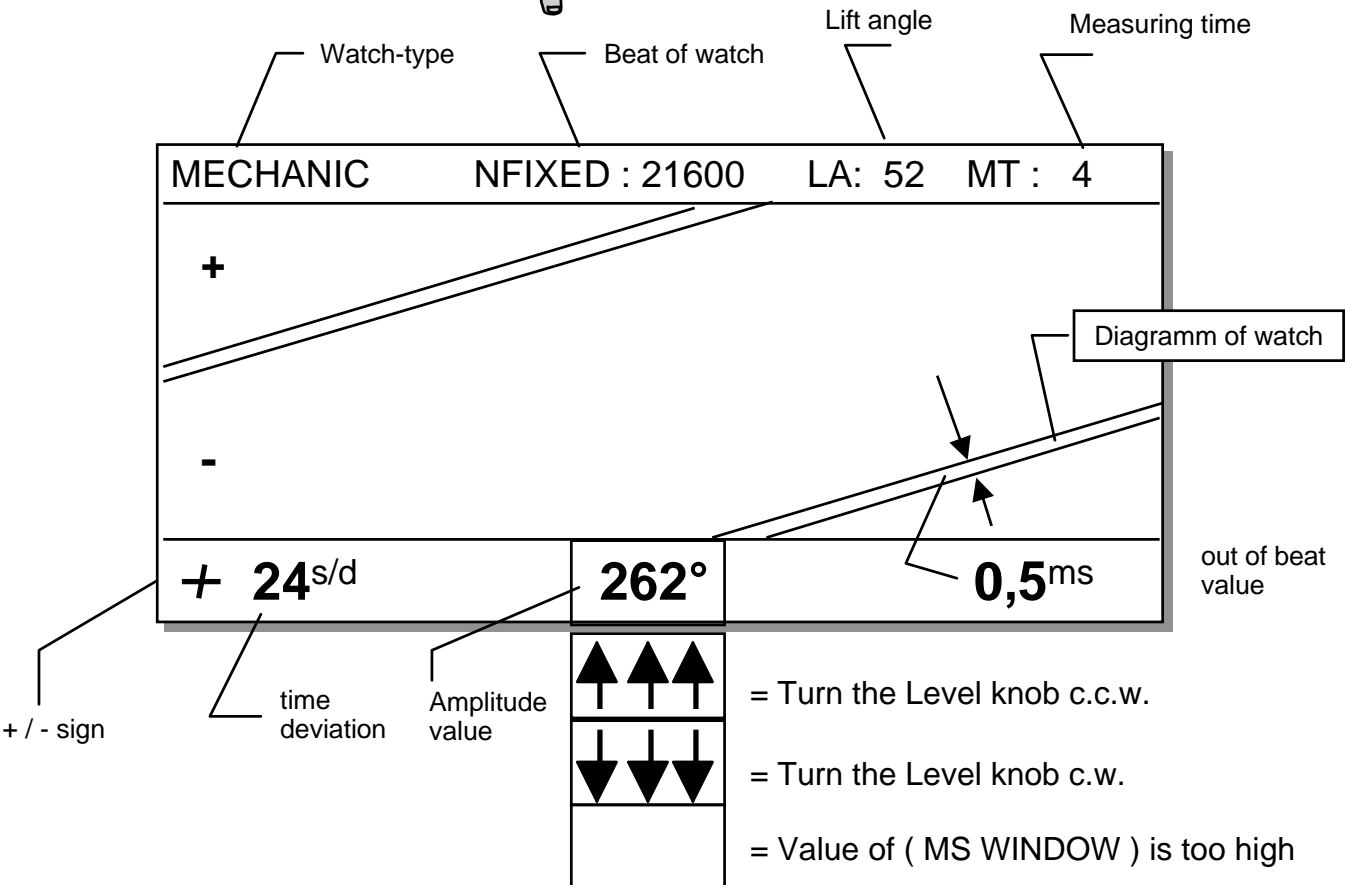
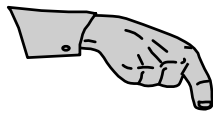

## Microphone MP86M for mechanical watches

The MP86M is a active microphone equipped with a high sensitiv cristal and electronic components.

Connect the microphonecable to the 15 pin male plug on the rear of the B 600.  
See also page x

The watchcase or the crown must touch correctly the activ front pins.

This pins, or so called fork , transmitts the watch sound (noise) to the cristal inside the microphone.

The cristal converts the noise in electrical signals.  
Through the built in electronic and the cable,  
the signals reaches the B 600.

The signals are converted in digital values and  
in a diagramm.



## Clamp - microphone for pocket-watches and clocks.

The clamp-microphone may be connected to the 15 pin male plug on the rear of the B 600 instead of the MP86M.



## Light barrier for clocks.

The light barrier may be connected to the 15 pin male plug on the rear of the B 600 instead of the MP86M.

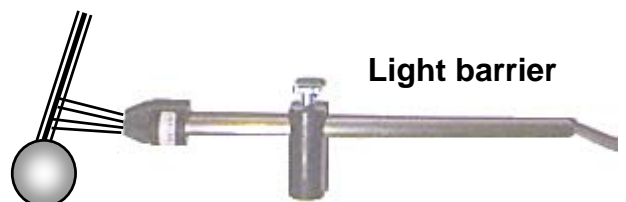

**1.1 The following parameters can be set in your (B 600)**

- a. Your preferred language : English , Dutch , French , Italian , German
- b. Your Name and Address : for printout together with results.
- c. Printer type : EPSON (FX 80 ) or compatible or, HP PCL or compatible
- d. Date & Time : Set the actual date and time of your country.
- e. Your preferred presettings after switching on the B 600.  
For example : Watch type, measuring time, automatic or fixed beat selection, etc.

**1.2 How to display the Configuration screen ? (picture 10)**

- a. Switch on the B 600 . Wait until the main menu is displayed.
- b. Press - PRINT- The following MENU is displayed in one of the 5 languages.

picture 10

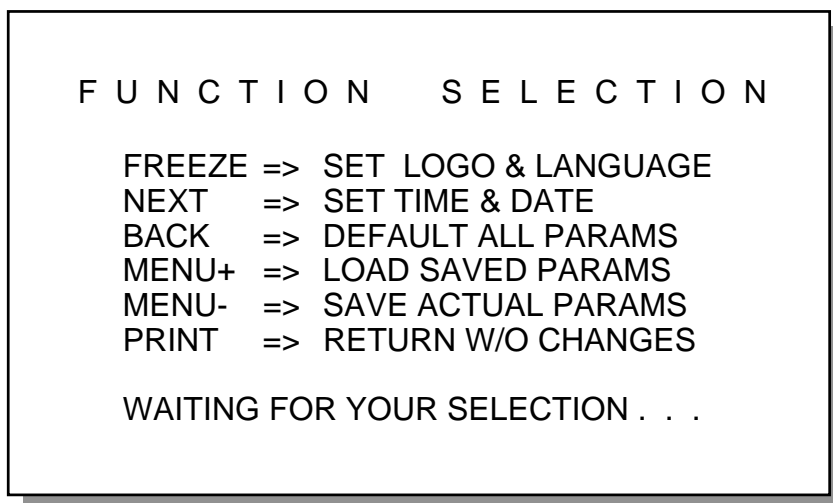

**1.3 Change the language**

- a. Execute step 1.2
- b. Press - FREEZE The corresponding Menu is displayed.
- c. Press - BACK / BACK / The language field is active.
- d. Press - MENU + press it until the desired language appears.
- e. Press - PRINT / PRINT / MENU - The selection will be stored.

From this moment, the B 600 works with the selected language.

**1.4 Enter your Name and Address**

- a. Execute step 1.2
- b. Press - FREEZE The cursor stays on the left side of the 2. line.
- c. Press - NEXT ..... Until the cursor stays on the position for the 1. sign.
- d. Press - MENU + or MENU - Until the desired sign appears.
- e. Press - NEXT ..... Until the cursor stays on the position for the 2. sign.
- f. Press - MENU + or MENU - Until the desired sign appears.
- g. Go on this way until the text looks as you wish.
- h. Press - PRINT / PRINT / MENU - The selection will be stored.

**1.5 Set Time & Date**

- a. Execute step 1.2
- b. Press - NEXT
- c. Press - MENU + or MENU -
- d. Press - NEXT
- e. Press - MENU + or MENU -
- f. Press - NEXT
- g. Press - MENU + or MENU -
- h. Press - NEXT
- i. Press - MENU + or MENU -
- k. Press - NEXT
- l. Press - MENU + or MENU -
- m. Press - NEXT
- n. Press - MENU + or MENU -
- o. Press - PRINT / PRINT / (MENU -)

Programmed Time and Date is displayed.  
 Cursor stays on hour.  
 Until the desired hour appears.  
 Cursor stays on minute.  
 Until the desired minute appears.  
 Cursor stays on second.  
 Until the desired second appears.  
 Cursor stays on day.  
 Until the desired day appears.  
 Cursor stays on month.  
 Until the desired month appears.  
 Cursor stays on year.  
 Until the desired year appears.  
 The selection will be stored.

**1.6 Set the desired test parameters**

- a. Switch on the B 600 and wait until the screen 1 is displayed :

**1.7 Set the desired test parameters for mechanical watches.**

- a. Press (Menu + ) to select the watchtype: MECHANIC

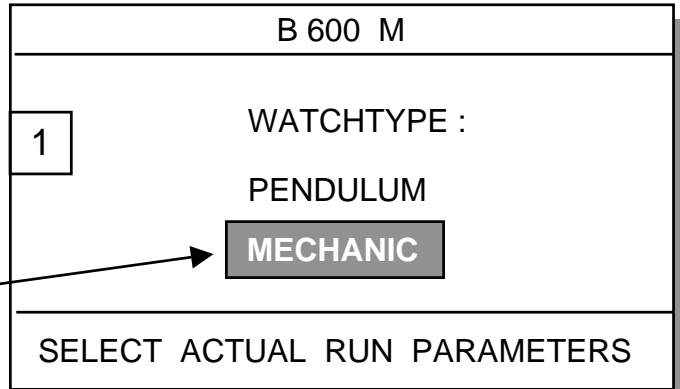

- b. Press (NEXT) screen 2 is displayed  
 By pressing (MENU + ) you may select AUTOMATCL beat selection or N FIXED

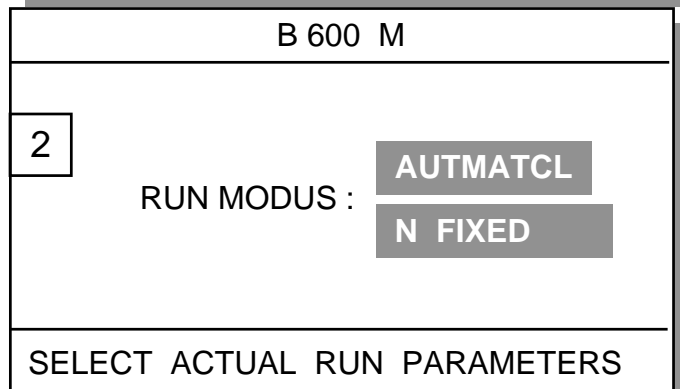

**AUTMATCL**

The B 600 detects automatically the beat of the watch.

**N FIXED**

The beat can be set manually from :  
 3600 to 36000 by steps.

**1.8 Set the desired MST LIFT ANGLE and BEAT FREQUENCY**

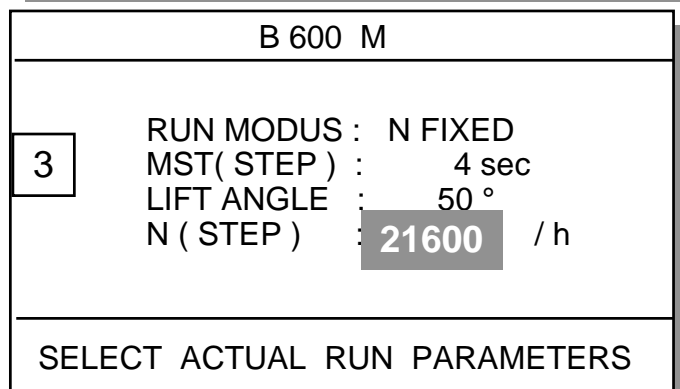

See next page for explanations !

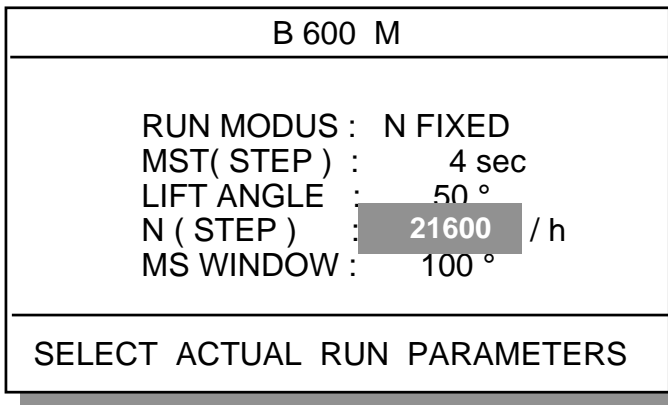

Press ( Next )  
to move down in this menu.

Press ( Back )  
to move up in this menu.

Press ( Menu + ) or ( Menu - )  
to change a value in the marked line.

Press and hold ( MENU + ) to increase  
Press and hold ( MENU - ) to decrease  
the value continuously

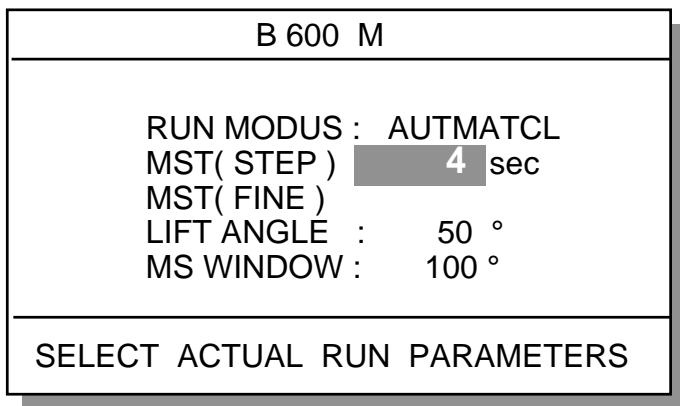

Measuring time : ( MST )

The result of time deviation will be  
displayed after the set value of ( MST )  
and will be the meanvalue of the ( MST )  
values in MST ( STEP ) are:  
4, 8, 12, 30, 60, sec.  
values in MST ( FINE ) are:  
2, up to 960 sec. in steps of 2

Lift angle: ( 50 - 52° )

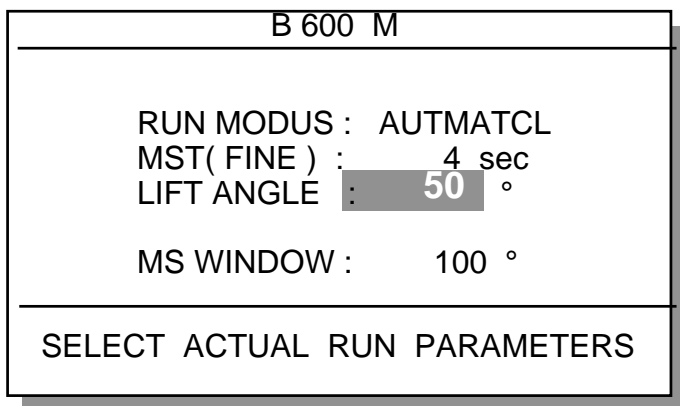

The value of lift angle depends on  
the construction of the watch. It is used  
in the B 600 to calculate the amplitude.  
Most watches have a lift angle of 50°-52°.  
It can be set from 30° up to 70°.  
If the value of lift angle is set lower than  
the value of the measured watch, the  
result of amplitude will be lower than  
it should be. If it is set higher the result of  
amplitude will be higher.

Beat frequency N ( STEP ) or N ( FINE )

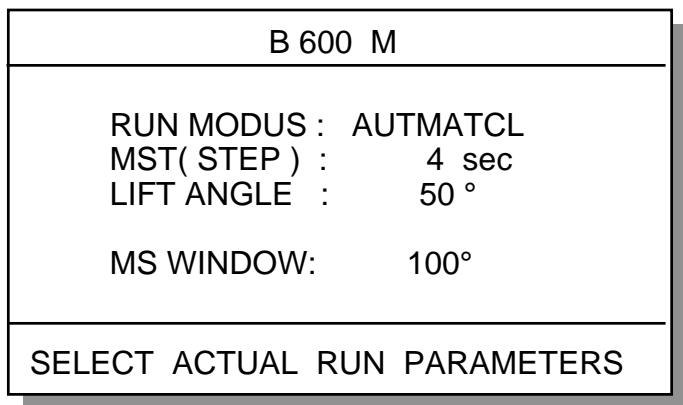

In RUN MODUS : **AUTMATCL**  
the beat frequency is automatically  
detected and set from the B 600 to a  
standard beat. Standard beats are :

3600, 4800, 7200, 7920, 8100,  
8640. 9360, 9440, 9720, 9760,  
14400, 16200, 18000, 19800, 21600,  
28800, 36000,

In RUN MODUS ( **N FIXED** )  
The beat can be set manually from  
3240 up to 39600 in N ( FINE )

### 1.9 Display and view of the watch escapement signal (noise) double or single beat

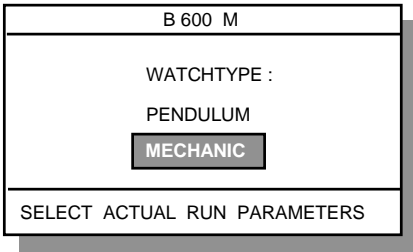

In this menu  
press FREEZE  
to display  
the double beat.

press START/STOP  
to return to the main menu

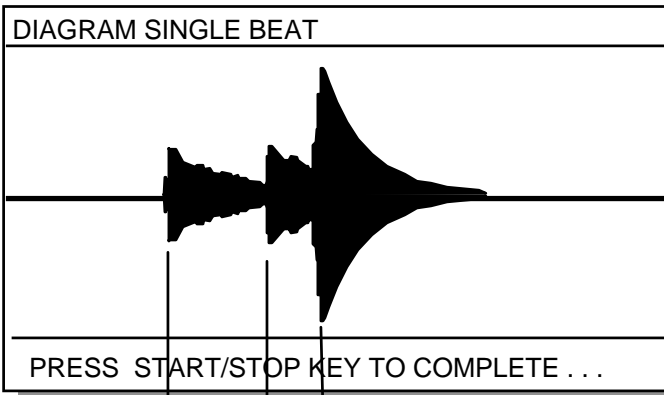
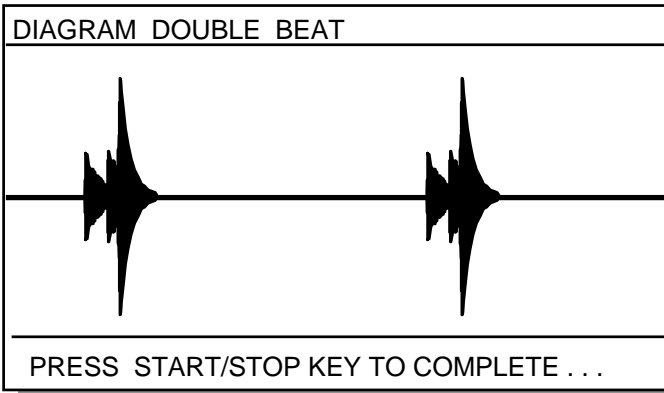
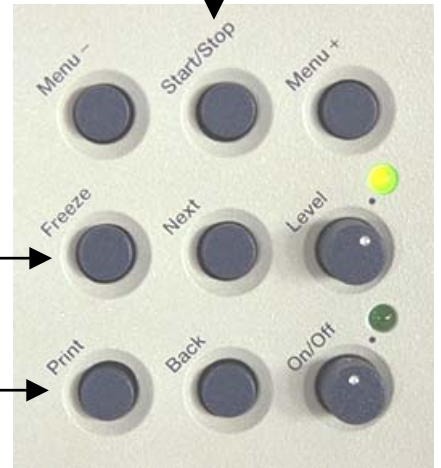

For more details.  
press PRINT  
to display the single beat.

press START/STOP  
to return to the main menu

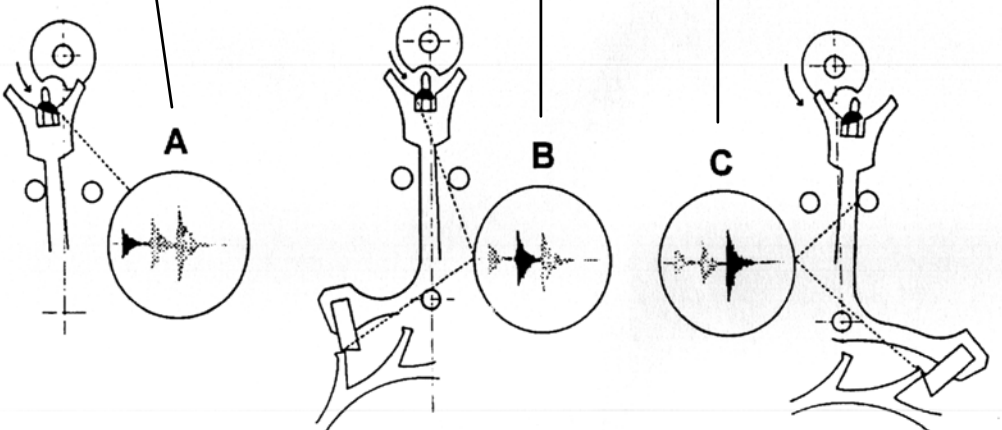

Escape system  
of the watch.



**2.0 CALCULATION OF AMPLITUDE**

The Amplitude depends on the following :

1. Beat per hour of the watch
2. Lift angle in degrees
3. Time between **A** and **C** in seconds

Terms :

Amp = Amplitude of balance wheel in °

$\angle$  = Lift angle in ° ( most watches have 52 ° )

t = Time between A and C ( in seconds )

n = Beat of the watch ( per hour )

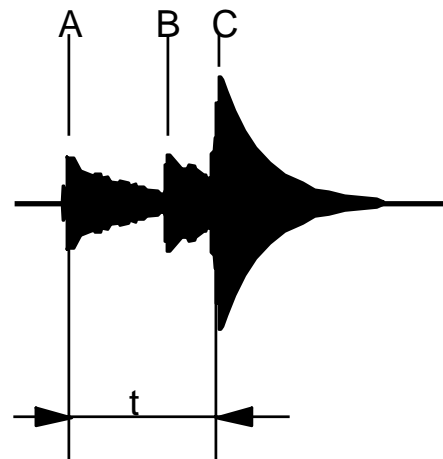

**Example :**

lift angle = 52°  
 n = 28800 beats / h  
 t = 0.009 s

**Formula :** 
$$\text{Amp} = \frac{(3600 * \angle)}{(t * \pi * n)}$$

$(3600 * 52)$	= 187200
$(0.009 * 3.14 * 28800)$	= 813.89
Amplitude	<u><u>= 230 °</u></u>

**Remark :** The value of the time ( t ) depends on the mechanical datas of escapement from the watch. This value is always measured by the B 600 and the amplitude is calculated. As you may see in the calculation example, this value is directly responsible for the result of amplitude.

**Conclusion :** The B 600 can calculate and display the amplitude of a watch very exact and stable, if the escapement noise is clear and stable. as it is in figure ( 1 )

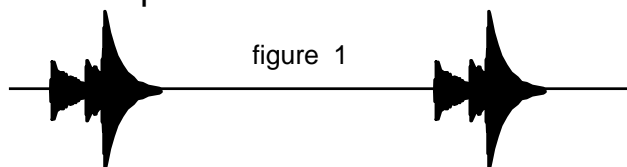

But it's impossible with a escapement noise as you can see in figure ( 2 )

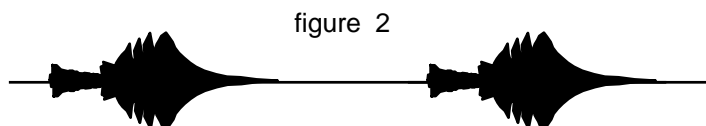

## 2.1 MS WINDOW ( Measuring window )

The measuring window has a factory setting value of 100° .

This means, the B 600 can display an amplitude value higher than 100° .

You may change this setting, if you have problems with the amplitude of certain watches.

B 600 M	
RUN MODUS :	N FIXWERT
MST( STEP ) :	4 sec
LIFT ANGLE :	52 °
MST (STEP) :	21600 / h
<b>MS WINDOW :</b>	<b>100 °</b>
SELECT ACTUAL RUN PARAMETERS	

If the escapement noise is not clear (because of mechanical problems of the watch, the noise signal may look as in figure 5 .

The value ( t ) is not always identically.

The B 600 may display a rong Amplitude , e.g 170° instead of 250°.

In this case you have the possibility to change the value called ( MS WINDOW ).

The value ( MS WINDOW ) is the minimum amplitude the B 600 can display.

If you increase the value to 220°, a real lower value will not be displayed. The place where amplitude normally is displayed, remains empty.

The MS WINDOW cuts a part of the escapement noise signal.

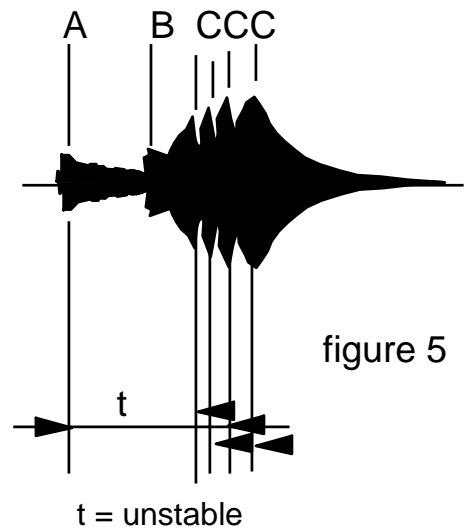

figure 5

B 600 M	
RUN MODUS :	AUTMATCL
MST( STEP ) :	4 sec
LIFT ANGLE :	52 °
N ( STEP ) :	21600 / h
<b>MS WINDOW :</b>	<b>180 °</b>
SELECT ACTUAL RUN PARAMETERS	

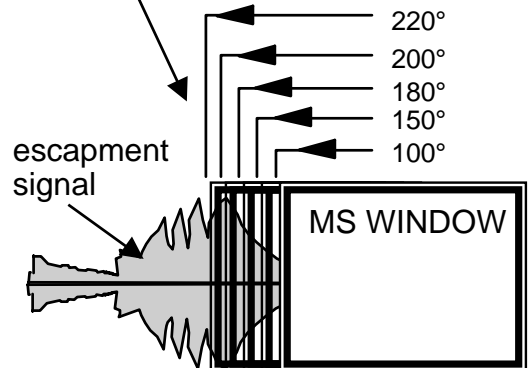

figure 6

To save the new value of MS WINDOW when in the above menu, Press ( PRINT ) first and then ( MENU - )

### 3.0 Clocks can be tested with a clamp microphone or a light barrier.

The clamp-microphone or the light barrier may be connected to the 15 pin male plug on the rear of the B 600 instead of the MP86M. See also page 1

#### 3.1 Testing Clocks with a light barrier.

- place the light barrier max 5 mm from the arm (pendulum).
- Switch the B 600 to PENDULUM pressing (MENU -)

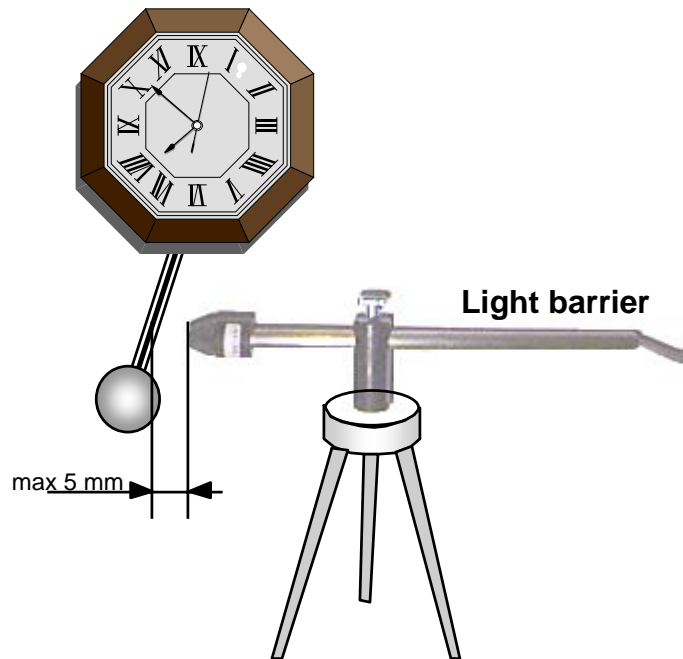
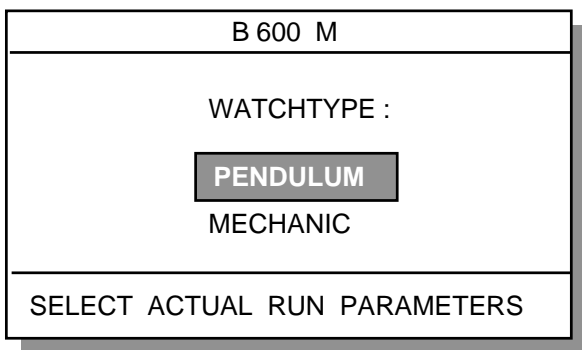

#### Clamp - microphone for pocket-watches and clocks.

The clamp-microphone may be connected to the 15 pin male plug on the rear of the B 600 instead of the MP86M.

#### Light barrier for clocks.

The light barrier may be connected to the 15 pin male plug on the rear of the B 600 instead of the MP86M.



**Microphone[Q]**

The QM4 has 2 microphones in one. The shown left side has the same function as the MP86M. For mechanical watches. The shown right side is equipped with 3 capture systems:  
 red point = capacitif LCD (quartz 4,19MHz )  
 metal pin = microphone for quartz 32 KHz  
 yellow point=inductif capture of motor impulses

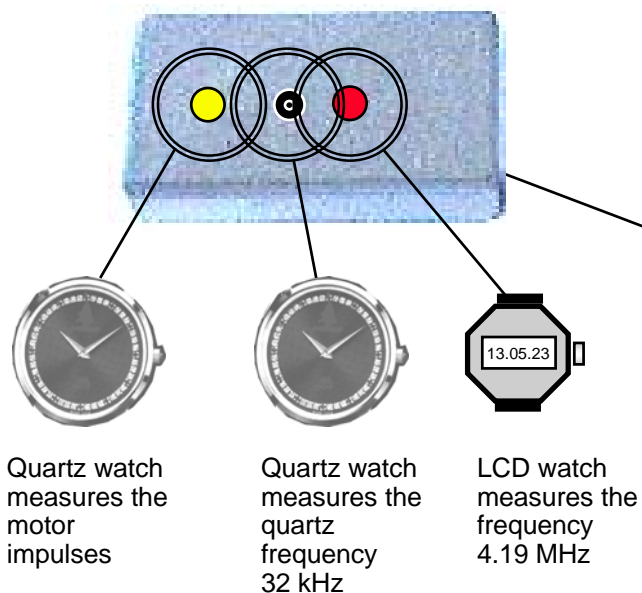
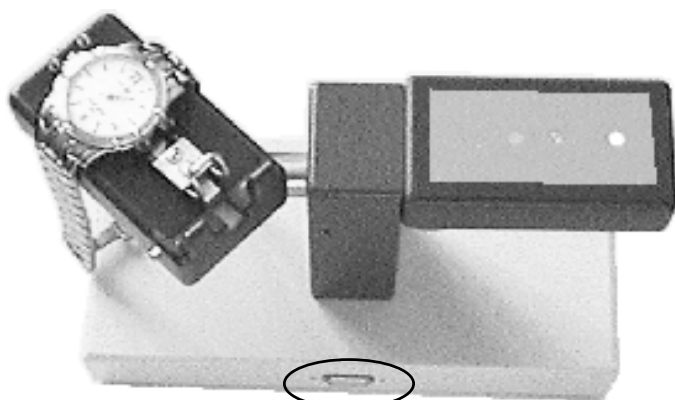

## *User Info about measuring of quartz watches On Vibrograf B600*

### **Explication of PRECISION**

( Float ) or ( /1 sec ) or ( / 10 sec ) or ( / 100 sec )

**Float** = The display of result on the left corner will be automatically set depending of the precision of the watch.

e.g. Result is displayed ( + 0.12 s/d )

-----

( / 1 sec )	Result is displayed	( + 0 s/d )
( / 10 sec )	Result is displayed	( + 0.1 s/d )
( / 100 sec )	Result is displayed	( + 0.12 s/d )

### **Explication of ( INDUCTIV ) ( DSPFRQCY ) ( TUNIFORK )**

**Quartz Frequency measurement** = measures the frequency of the quartz inside the watch. Lay the watch on the metal Pin. The microphone will display the deviation of the Quartz frequency of the watch.

**INDUCTIV** = Motor impulses measurement

Put the watch on the yellow point. Each motor impulse will be displayed with A arrow in the lower part of the display.

For example quartz watches with 1 second impulses

Or quartz watches with inhibition of ( 10 sec. 20 sec. 60 sec. For example.)

**DSPFRQCY** = LCD Frequency signal

For the measurement of Display ( LCD ) Signal measuring.

Only possible with standard LCD Display watches with a display frequency of 64 Hz. Lay the watch on the red point with the display downwards and

If possible at the same time make contact with the metal case of the watch with the metal pin in the middle of the microphone. ( grounding )

**TUNIFORK** = Tunifork watches ( antique style watches)

For example ( OMEGA electronic f 300Hz ) Seamaster Chronometer

Put the watch on the yellow point.

Preferably choose a measuring time of min. 8 sec. ( stability of result )

And the ( DSP Y Gain to 20 )

By changing the ( DSP Y GAIN ) „Display gain „ the grafic line will change.

Please try once

**EXAMPLE for ( DSP Y GAIN ) ( 1,2,5,10,20,50,100,200,500 )  
Same watch ( + 0.12 s/d )**

**The higher you set the (DSP Y GAIN) value ,  
The higher is the resolution of the displayed graphic.**

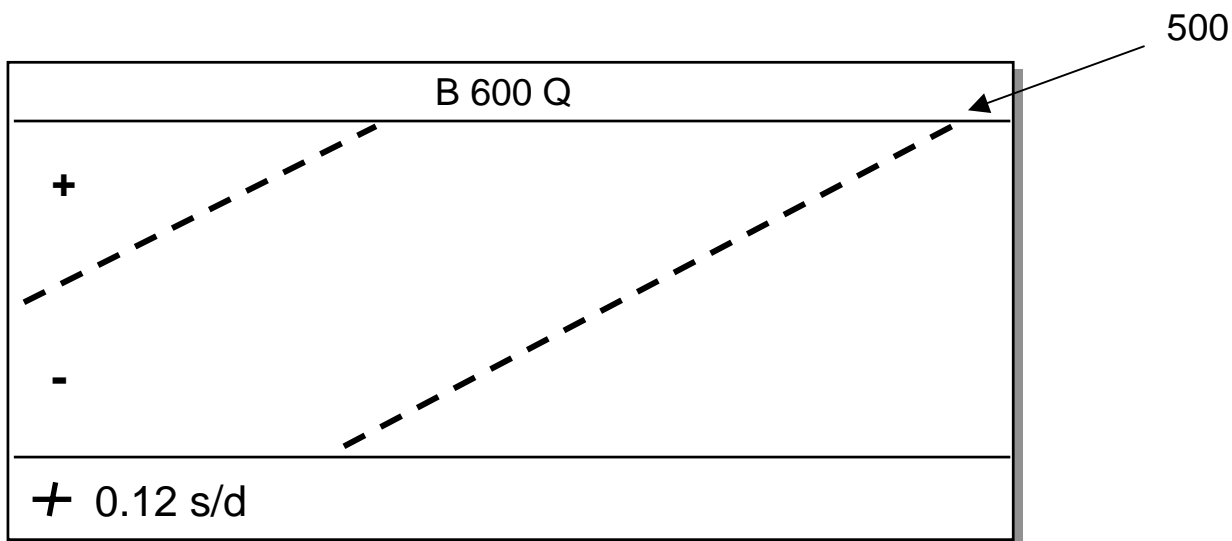
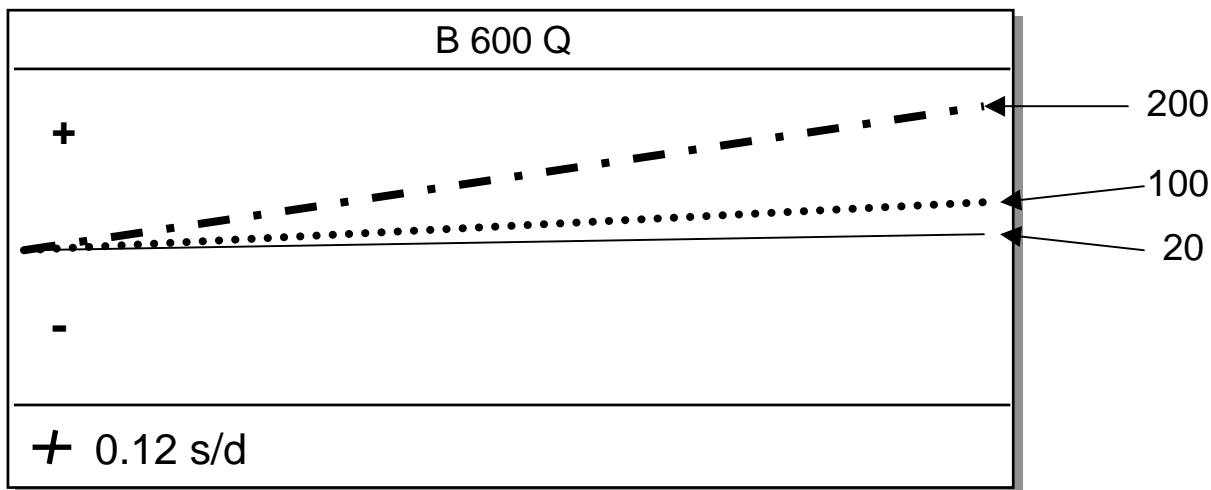

# Calibrating and adjustment on your B600

Front of B600

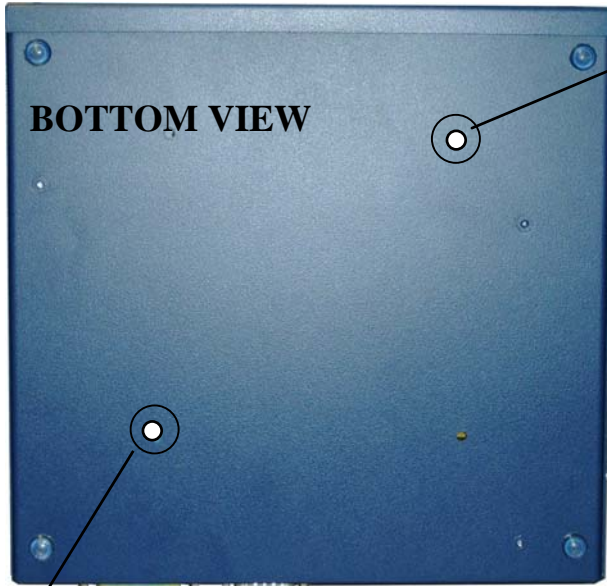

**Ajustment of brightness and contrast of B600 display.**

When it needs adjustment?  
Depending on where you put the B600 and from which angle you are looking in the display it may be necessary to adjust the contrast .  
How to adjust?  
Switch on the B600,.  
Turn the potentiometer in either c.w. or c.c.w. direction while you watch the changement of the display brightness and contrast.

Rear of B600

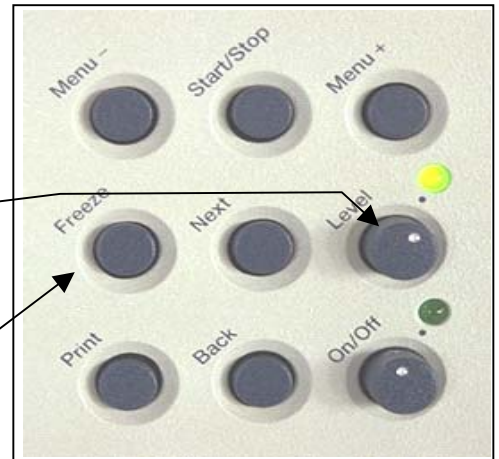

**Amplifier for the signal of the microphone**  
**When it needs adjustment?**

If you have the impression that the watch signal is too weak and the grafic gives problems.

**How to adjust?**

Turn the Knob ( Level) in front of the B600 in the position one o'clock ( point to point )  
Lay a good working watch correctly on the microphone.  
On the B600 press the Freeze button and watch the Oscilloscope signal of the watch noise.  
Turn the Pot meter on the bottom of the B600 slightly in one direction.  
The oscilloscope signal should touch the upper and lower line. O.K. that's all

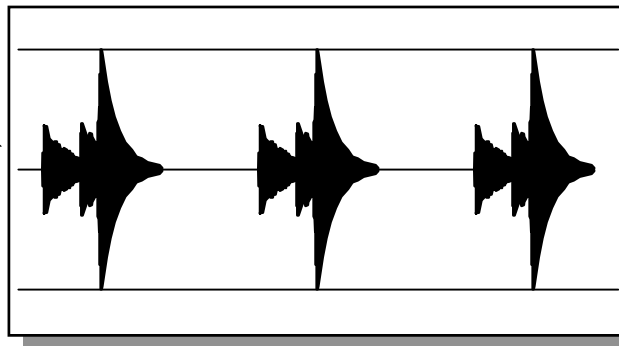

**Adjustment of internal quarz frequency**

The calibration is reserved for service only



With this potentiometer the B600 can be calibrated .  
This means , the internal quarz frequency will be adjusted.  
To calibrate the instrument correctly ,you need a master signal , e.g. DCF77.  
The calibration is reserved for service only

weight = 3.0 kg

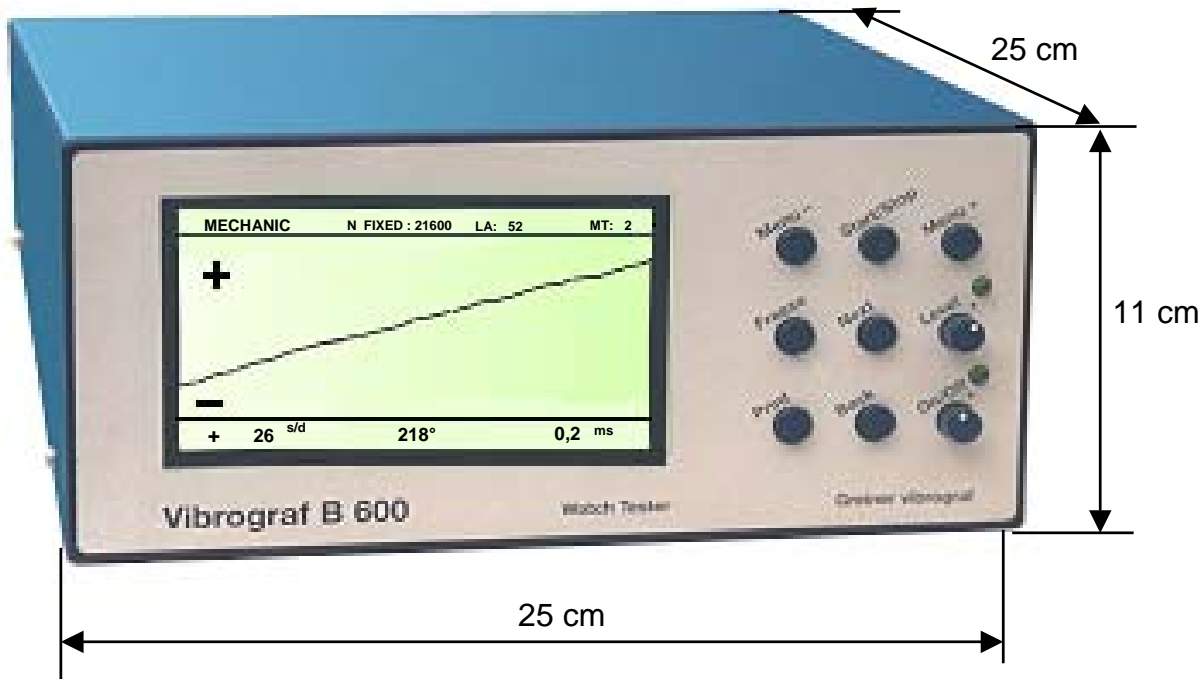

- Power supply : 230 V , 50/ 60 Hz  
115 V , 50/ 60 Hz (adjustable inside)
- Power consumption: < 20 W
- Time base: TCXO - Reference-oscillator  
Precision: 1 ppm ( < 0.1 s/day)
- Connections: Power supply plug  
plug for microphone  
serial plug ( not active)  
parallell printer connector
- Display: 1 LCD Display, adjustment of brightness  
with potentiometer on the rear
- Functional sequence: 2 LED's, printing and measuring
- Measuring possibilities: mechanical watches:  
beat frequency (automatic and manual)  
out of beat value  
amplitude  
time deviation  
visualisation on display of beat noise  
electrical watches  
32 kHz quartz frequency  
4.19 MHz quartz frequency  
frequency of digital display  
motor impulses
- Optional devices: clamp microphone  
optical system for clocks