

Operating and Maintenance Manual

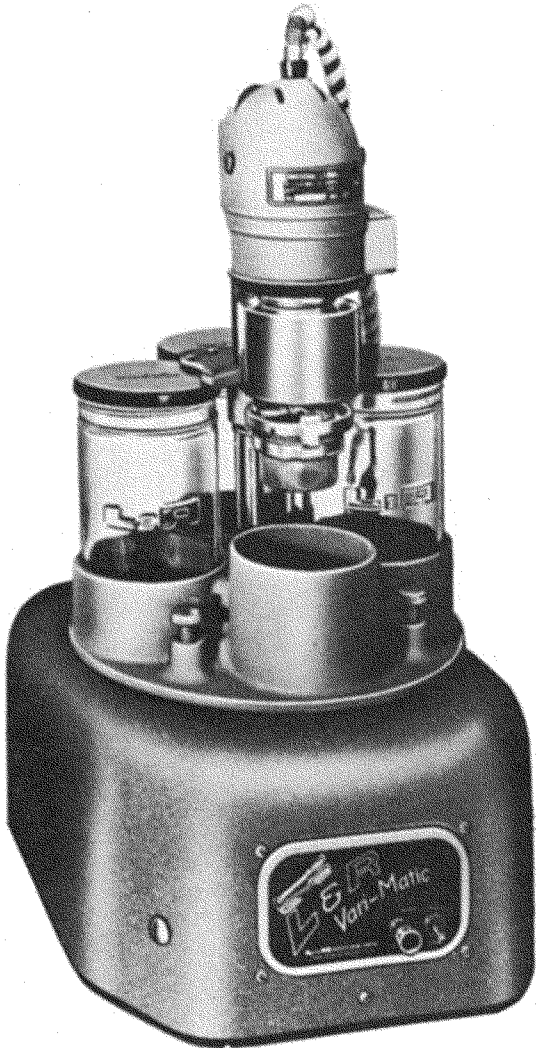

VARI-MATIC & VARI-MATIC II



Read this Operating and Maintenance Manual carefully for the proper way to operate and care for your L & R Vari-Matic Watch Cleaning Machines.



WATCH CLEANING MACHINES



MANUFACTURING COMPANY

Main Offices and Plant
577 Elm Street, Kearny, N.J. 07032 • Telex: 642078 Ellanar Krny.

INDEX

■ OPERATING INSTRUCTIONS

	Page
<i>How to Remove Machine from Crate</i>	3
<i>Things You Should Know and Do</i>	3
<i>Important Points to Remember</i>	4
<i>How to Test Run Your Machine</i>	4
<i>Cleaning and Rinsing Solutions and Jars</i>	4
<i>How to Operate Your Machine</i>	5
<i>Recommendations for Best Results</i>	5

■ MAINTENANCE INSTRUCTIONS

<i>Bleeding the Hydraulic System</i>	6
<i>Adjusting Basket Height</i>	7
<i>Adjusting the Time Cycle</i>	8
<i>What to Do if Electric Power Fails</i>	8
<i>Machine's Switches</i>	8
<i>Adjusting Basket Motor Speed</i>	9
<i>Drying of Parts and Spin-Off</i>	10
<i>Helpful Maintenance Hints</i>	10
<i>Machine Diagram and Parts List</i>	11
<i>Wiring Diagram</i>	12
<i>Hydraulic System Diagram</i>	13

HOW TO REMOVE YOUR L & R VARI-MATIC WATCH CLEANING MACHINE FROM SHIPPING CRATE

Remove the *top* and *front* of the crate. SEE ILLUSTRATION for how the crate should look.

Remove the contents in the corrugated partitions in the top of the inside liner. Check them against this list:

- 1 Qt. Extra Fine Cleaning Solution ● 1 Qt. Rinsing Solution
- 3 Jars with Stars ● 1 Bleeder Cup ● 1 #1 Basket Complete
- 1 Clock Basket & Top ● 1 Set Multiple Inserts for Clock Basket
- 1 Divider Partition and Cover ● 1 Bottle Hydraulic Fluid
- Instruction Manual ● Registration Card and Warranty.

Remove all corrugated parts from the crate.

THIS IS IMPORTANT — THE MACHINE IS BOLTED TO THE BOTTOM OF THE CRATE.

HERE'S HOW YOU REMOVE THE THREE BOLTS: Tip the crate or slide the crate out over the edge of a table. This will expose the bolts. Remove them.

SLIDE THE MACHINE OUT OF THE CRATE — DO NOT LIFT BY THE MOTOR OR TURNTABLE . . . EVER! IF YOU DO, YOU MAY DAMAGE THE MACHINE.

HERE'S HOW TO CARRY THE MACHINE — CARRY IT BY THE BOTTOM! This machine is a precision-built instrument. If you carry it by the motor or turntable, you will *damage* the operating mechanism.

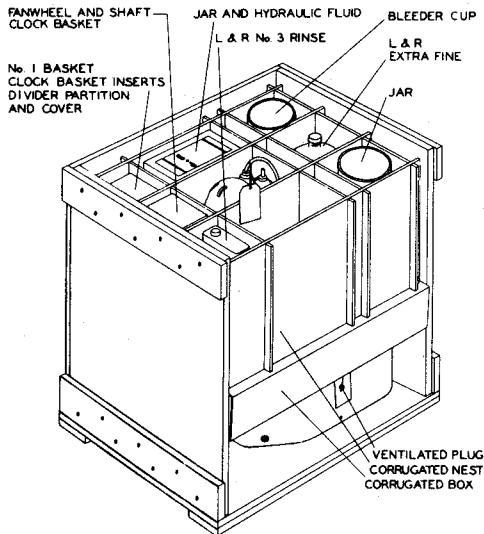

THINGS YOU SHOULD KNOW AND DO BEFORE TRYING TO OPERATE THE MACHINE

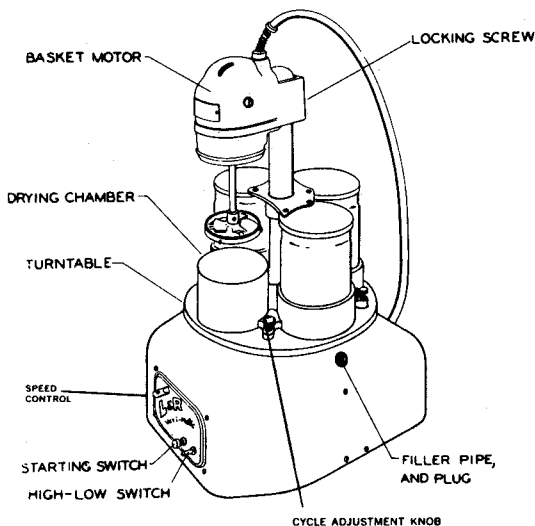

1. **THE HYDRAULIC FILLER PIPE AND PLUG.** The screw in this plug **MUST BE REMOVED** in order to permit the Hydraulic System to breathe. The screw should only be replaced when shipping the machine.
2. **CHECK YOUR ELECTRIC CURRENT.** It must be between 110 and 120 volts, Alternating Current. This machine will operate on 110 to 120 volts, 60 cycle, **AC ONLY!** **CAUTION:** This machine will not run on DC current. If it is plugged in on DC current, *serious damage* to the motors will result!
3. **THE BASKET MOTOR** is set at the factory in drying position to conserve space for shipping. When you switch on your machine, it will continue on to the "at rest" position or end of cycle and stop.
4. **THE MACHINE'S CONTROLS.** Read the description below for the function of each.
 - a. **THE HIGH-LOW SWITCH** turns the machine and **PILOT LIGHT** on ready for operation. *Low speed* is used when the machine is operated with the *Watch Basket*. *High speed* is used when you use the larger *Clock Basket*. At night, to *turn machine off*, put switch in center position between High and Low. Should the machine be left on overnight, no possible harm can result. The amount of current used is negligible and the machine is inoperative until the Push-Button starting switch is depressed.

- b. **THE PUSH-BUTTON STARTING SWITCH.** This switch starts the cleaning cycle. It is also used to raise the cleaning motor and go on to the next step in the cleaning cycle if you want to *hasten* the cleaning operation.
- c. **THE CYCLE ADJUSTMENT KNOBS.** These knobs are used to adjust the length of time the basket motor will remain in the position immediately to their right.
- d. **SPEED CONTROL.** This is used in order to adjust the speeds of the basket motor where necessary to compensate for the variations of voltages in different sections of the country. If the basket motor runs too fast or too slow because of power supply, simply remove the *Hole Plug* at the lower left of the machine, insert a screwdriver and turn the rheostat slightly to the left to reduce speed or to the right to increase speed. No further adjustment is required once the desired speed has been obtained.

THESE ARE THE IMPORTANT POINTS TO REMEMBER WHEN YOU OPERATE YOUR MACHINE

1. Adjust High-Low Switch to desired position.
2. Push the Push-Button Switch to start the cleaning cycle. When cycle is complete, the machine will automatically come to rest.
3. If, for any reason, you wish to shut off the machine at any point in the cleaning cycle, the machine can be turned OFF by putting the High-Low Switch in the center position.

HERE'S HOW TO TEST RUN YOUR MACHINE

FOLLOW THESE STEPS

1. *Plug in line cord.* You will note the plug has an additional connection. This is for grounding the machine. Replace the outlet receptacle plate screw with the screw on the green wire at the plug for a suitable ground.
2. *Do not put solution jars in turntable for this test run.*
3. Put High-Low Switch in Low position to start the cleaning cycle.
4. While machine is running through its cycle, *watch for these important points:*
 - a. When the basket motor is in its lowest position near the turntable, the motor shaft should rotate in one direction at high speed—it only reverses while on the jars.
 - b. In the mid-raised position (spin-off), the shaft should rotate in one direction *only*.
 - c. The turntable should turn while the basket motor is at its highest level—this is when the outer column rises above the scribe line on the inner column.

A WORD ABOUT THE CLEANING AND RINSING SOLUTIONS AND JARS

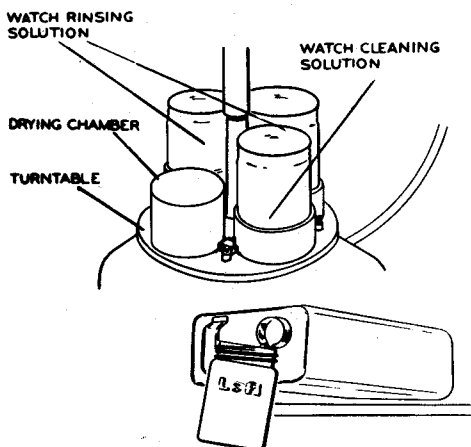

In shipping, paper and dust may accumulate in the jars. Remove the stars carefully from each jar and *wash* and *dry* jars and stars with a *lint-free* cloth. Replace the star in each jar on the bottom.

How to fill the jars with the cleaning and rinsing solutions. In one jar, pour **L & R Extra Fine Watch Cleaning Solution** to the middle of the letters **L & R** on the jar. Place it in the opening to the right of the drying chamber on the turntable as illustrated. Twist jar in opening so that it rests freely and straight. In the other two jars, place the same amount of **L & R No. 3 Watch Rinsing Solution**. Put these jars in the other two openings on the turntable as illustrated.

The best way for solutions to be poured is with the nozzle of the can upward and resting on the jar. If the jar is placed at a slight angle away from the can but touching the nozzle, **no spilling will result.**

YOUR L & R MACHINE IS NOW READY FOR SERVICE— HERE'S THE BEST WAY TO OPERATE THE MACHINE

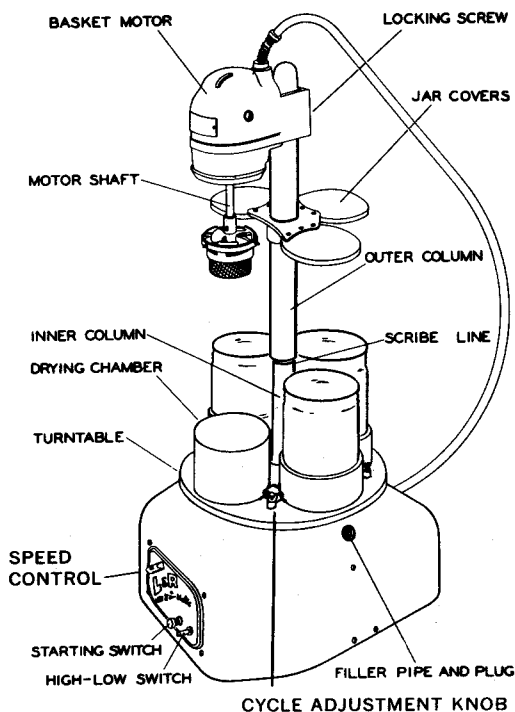

Your machine has been supplied with several baskets. *When using the Watch Basket, the machine should be operated at Low speed. When using the Clock Basket with inserts, use the High speed. The machine is used at High speed when using the Clock Basket in order to compensate for the heavier load. Actually, the basket will rotate at the same speed as in Low when using the Watch Basket.*

Place the High-Low Switch at the desired position.

Press the Push-Button and hold it for 2 or 3 seconds until the basket motor starts to rise, then release button.

HERE'S WHAT WILL HAPPEN—the cleaning basket will rise and the turntable will turn to the first step in the cycle. The basket will be lowered into the cleaning solution in the jar. It will operate approximately for three minutes with reversing movement. Then the basket will rise to spin-off position and will spin-off in *one direction* for about 7 seconds. The entire process will then repeat itself in the *first and second* rinse jars. After the second rinse the basket will be lowered into the drying chamber where it will rotate in one direction at reduced speed for about three minutes. Then the basket will rise and come to a complete stop directly over the drying chamber.

FOLLOW THESE RECOMMENDATIONS FOR THE BEST RESULTS

1. Completely disassemble all watches to be cleaned.
2. Avoid placing two large flat surfaces together in one basket.
3. Train wheels, escapement and screws should be placed in the indented compartment on the basket tray.
4. You will note that the basket tray cover has a depressed side. Place this side down over the basket tray. The depression will keep all small parts in the tray.
5. When attaching the basket to the fanwheel and shaft, hold the fanwheel with one hand with slight downward pressure while attaching the basket with the other. Hold basket by the frame—NOT the mesh!
6. Best results are assured when you use *L & R Watch Cleaning and Rinsing Solutions*. They were designed for use with each other and were specifically intended for use in this machine. They provide you with highest efficiency and best results.
7. Do not under any circumstance use GASOLINE, BENZINE, BENZOL, BENZENE OR CHLORINATED SOLVENTS SUCH AS CARBON TETRACHLORIDE, TRICHLOROETHYLENE AND PERCHLOROETHYLENE.

CHLORINATED SOLVENTS ARE HIGHLY CORROSIVE ON WATCH PARTS AND *VERY DANGEROUS* TO YOUR HEALTH. GASOLINE AND BENZINE ARE HIGHLY EXPLOSIVE AND EXTREMELY HAZARDOUS TO THE RED CORPUSCLES IN THE BLOOD OF THE HUMAN BODY.

HERE'S HOW TO ADJUST OR SERVICE YOUR L & R VARI-MATIC WATCH CLEANING MACHINE

BLEEDING THE HYDRAULIC SYSTEM

The Trouble: The basket motor and outer column shaft does not rise and clear the scribe mark on the inner column or does not rise at all. Basket motor does not rise high enough to clear jar and locks up against jar when turntable is turning.

The Cause: Air has entered the *Hydraulic System* or there has been an exhaustive loss of Hydraulic Fluid.

The Remedy: Bleeding the Hydraulic System to remove air or adjusting basket height. See page 7.

INSTRUCTIONS ON HOW YOU CAN DO THIS

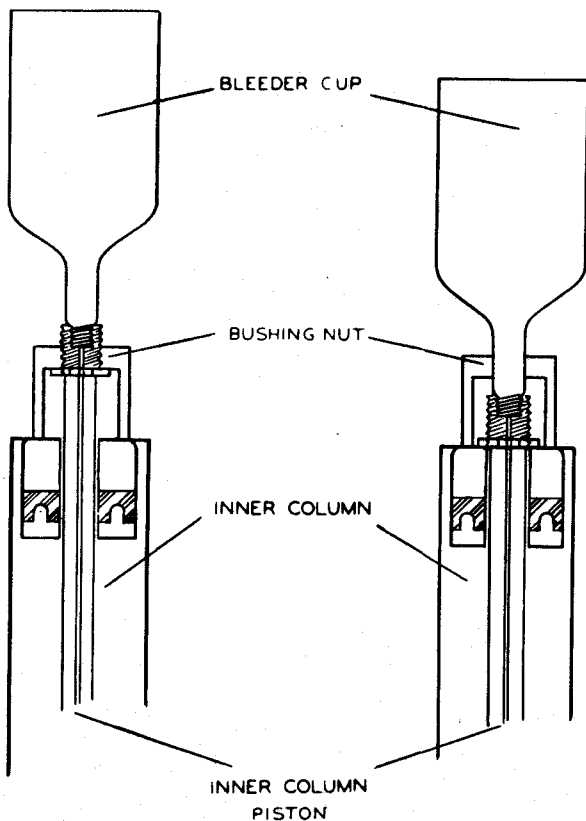

1. If the machine is jammed, it will be necessary to remove the rear half cover. To free the machine the circular cup found at the drive motor should be turned clockwise by hand. This will reverse the machine enough to permit repair.
2. Unplug the motor from the machine. Remove fan-wheel motor and the outer column by lifting the assembly off the machine.
3. Place High-Low switch at low position and operate the machine until the column piston is in its lowest position, then shut the machine off by placing High-Low switch in center-off position.
4. Screw bleeder cup into column piston tightly. It will help to place a dab of grease or vaseline on the threads to prevent the possible re-entry of air.
5. Loosen lock nut and bushing nut by turning them counter-clockwise until they clear the inner column piston.
6. Then, push Bleeder Cup down.
7. Remove vented filler pipe plug gauge and pour fluid into pipe to fill reservoir to level.
8. You can check the Hydraulic Fluid level by removing the filler plug to which a gauge for the oil is attached. If the end is wet when the column is at its highest point, there is sufficient fluid in the reservoir.
9. Reservoir should be refilled every time the turntable makes one complete revolution during the bleeding operation.
10. Hold Push-Button in. Oil and air bubbles will be seen rising in the Bleeder Cup. *Note:* If bleeding operation correctly follows the above instructions, the column will not rise but the turntable will turn.

(cont'd)

INSTRUCTIONS ON HOW YOU CAN DO THIS (cont'd)

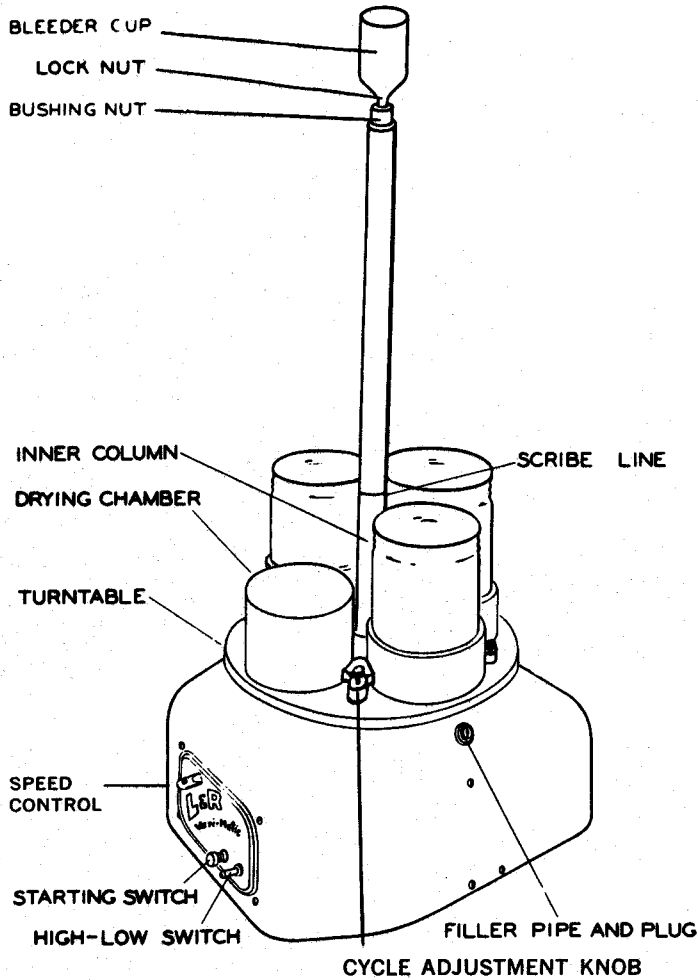

11. Should the Bleeder Cup become filled with oil before the system is completely bled, it will be necessary to follow the instructions in paragraphs 13 and 14 and remove the cup to empty the oil and then replace the cup for bleeding operation as described before.
12. Push-Button must be held in until air bubbles cease to appear. When they no longer appear, the system has been bled.
13. When machine is bled, pull Bleeder Cup upward just enough to engage the bushing nut, then tighten down bushing nut and locking nut.
14. Unscrew Bleeder Cup from piston.
15. Replace outer column and motor.
16. The machine should now operate properly and the outer column should clear the scribe mark on the inner column between $3/16$ " and $1/2$ ". If it exceeds this figure, recheck bleeding operation. If this doesn't correct the fault, see instructions for "Adjusting Basket Height."
17. Use *L & R Hydraulic Fluid only*. It has been especially compounded for this machine. Don't use brake fluid or any additive because they will damage the machine parts.

ADJUSTING BASKET HEIGHT

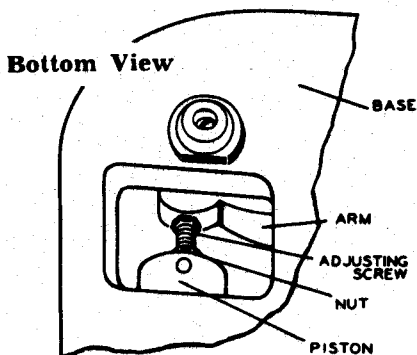

The Trouble: *Basket is too high or low*—in spinning-off too high it splatters the the solution and spinning-off too low it stirs up the solution and wets parts in the bottom of the basket.

The Cause: Outer column does not clear scribe mark on inner column.

The Remedy: Slide machine over edge of table. You will note piston and adjusting screw. Loosen locking nut with a wrench and turn screw out to raise and in to lower basket. To keep piston from turning when loosening the locking nut, insert a pin in the hole provided in the piston. Tighten locking nut after adjustment is made. You can simplify and assure proper adjustment by making the adjustment when the outer column is at its topmost position so that the scribe mark on the inner column is visible when setting.

ADJUSTING THE TIME CYCLE

This machine incorporates the new Vari-Matic cycle control. The ultimate in flexibility of cleaning cycles is now obtainable in that each individual cleaning, rinsing and drying position can be adjusted from a minimum of 1½ minutes to a maximum of 8 minutes.

How to make this adjustment:

There are 4 adjustment knobs on the turntable. Each knob will regulate the length of time that the position immediately to its right will have. They are marked for easy identification. There is a small indicator just behind each knob. This indicator will gage the approximate time that the position is set for. The machine is set at the factory for 3 minutes in each position.

To lengthen the time, simply screw down the knob clockwise until the desired time is obtained. To shorten the time, screw the knob counterclockwise or up.

Adjustment of the time cycle must be made before each station comes into position. Adjusting the time cycle while it is in position will not alter the time for the station until the machine is fully indexed again. The indicator is marked with 3 horizontal lines. When the top of the knob is even with the top line on the indicator the timer will trip after about 1½ minutes. With the top of the knob even with the second line, the machine is set for 3 minutes and when the top of the knob is even with the third line 5 minutes of time is obtained. To obtain maximum time screw the knob all the way down. The adjustment is continuously variable. Any desired time within the limits of maximum and minimum can be obtained. Some care must be observed when shortening the time cycle since if it is screwed up too far the knob will fail to trip the timer lever with the result that the motor will not remain in the desired position but will come out immediately and proceed to the next stage.

It should be remembered that if any position is set to a long time cycle and this is consequently shortened by pressing the push-button starter switch without waiting for the complete time, the following position will automatically take over the balance of this time since the timer has not reset itself.

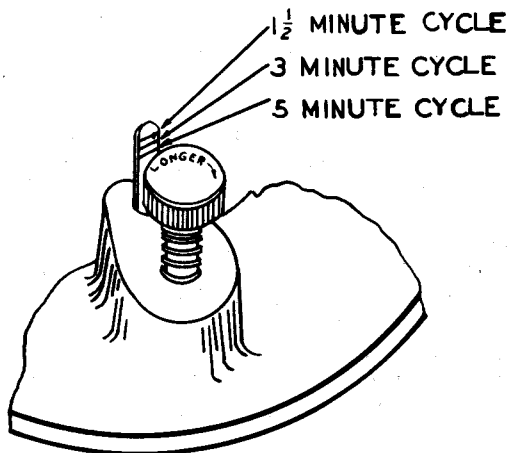

WHAT TO DO IF ELECTRIC POWER FAILS OR IS TEMPORARILY SHUT OFF WHEN PARTS ARE IN THE CLEANING OR RINSING SOLUTIONS

If ever the electric power fails, your machine will stop and then start and finish the cleaning cycle when the power is resumed.

If the electric current is not resumed promptly and parts are in the basket in the cleaning or rinsing solutions, you can remove the parts from the basket by first shutting off the machine. Loosen the set screw that fastens the motor to the column and lift the motor and basket off the machine. Immerse parts immediately in rinse. Return parts to basket when power is resumed. Start machine and it will continue the cleaning cycle from the point where the power failed.

THE MACHINE'S SWITCHES

HERE'S WHAT THEY CONTROL

Switch A—the top switch in the rear stack of three controls the basket motor operation.

Switch B—the second switch in the stack controls the main 1/10 H.P. indexing motor.

Switch C—the lower switch on the stack is in series with **Switch D**, the upper switch of the forward stack. These switches, operating in conjunction with each other, stop the machine at the end of the cycle. When they are both open, the machine will not operate.

Switch E—the lower switch in the forward stack reduces the speed of the basket motor in the drying position. If the speed of the motor in the drying chamber is equal to the speed of the basket motor when in the spin-off position, this switch is inoperative.

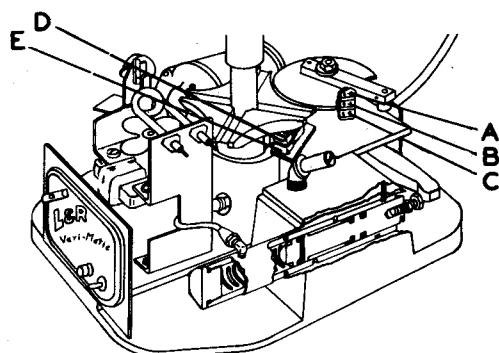

HOW TO ADJUST SWITCHES

It will be generally found that if one switch fails to function properly, the phenolic cam actuating these switches should be adjusted slightly. The plate on which the switches are mounted, should be tapped in towards the center of the machine and the two socket cap screws tightened.

HOW TO ADJUST BASKET MOTOR SPEEDS

It will first be necessary to remove the Hole Plug and increase or decrease speed in all cleaning positions as explained in "Controls Section", Operating Instructions. If the desired speed for one position is obtained, but not for the others, follow these instructions:

Remove front cover by removing the screws from the front cover and the four self-tapping screws that retain the panel—then remove cover.

HERE'S HOW YOU MAKE THE ADJUSTMENT

1. To the front and left of the machine you will see an adjustable resistor assembly as illustrated. This resistor controls the various speeds of the basket. *Refer to drawing for position of the following:*
Slider "A" (Orange Wire)—this controls the basket speed in the drying position.

Slider "B" (Purple Wire)—this controls the basket speed with the switch in the Low position.

The Purple Wire at the rheostat controls the basket speed with the switch in the *High* position.

2. Moving the Sliders A and B toward the rheostat will increase the speed of the basket motor. Moving the sliders away from the rheostat will decrease the speed. To change the speed of the motor with switch in *High* position, adjust rheostat.

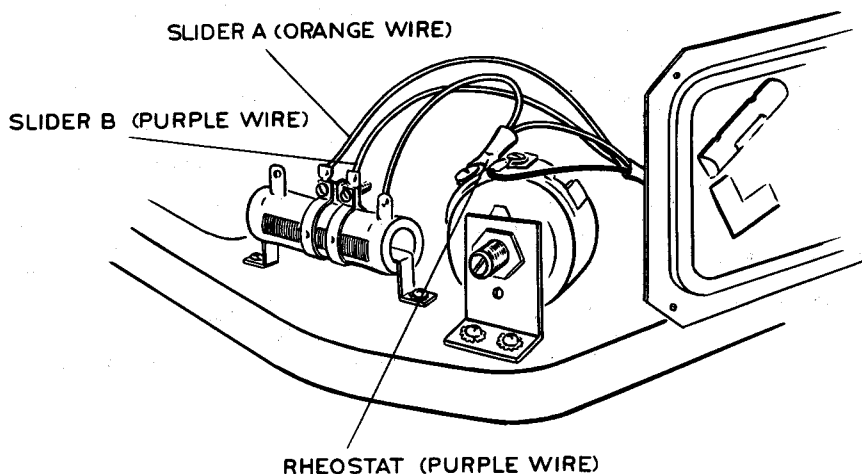

■ DRYING OF PARTS AND SPIN-OFF

This machine uses a "Cal-Rod" type heater with a rating of 300 watts. It has enough heating power to dry the watch parts normally put into the basket. Directly below this heater element is a fan motor which serves to blow the warm air over the watch parts.

SPIN-OFF SPEED AND TIME

Spin-off of excess solution is extremely important. Not only does it serve to keep the solutions in the jar in which they belong but it also has the added advantage of leaving less solution in the basket to be dried.

Spin-off time is approximately 7 seconds. This time cannot be changed, nor need it be. However, the speed of spin-off can be changed. This speed governs its efficiency. The spin-off speed is controlled by the cleaning speed. In other words, the faster the motor turns while in solution the faster it will turn in spin-off and vice versa. See page 9—How to Adjust Basket Motor Speeds.

If conditions are such that the parts come out of the machine insufficiently dry, try any or all of the following suggestions.

1. Increase spin-off speed (page 9).
2. Increase drying time cycle.
3. Remove front cover and decrease the pitch of the fan blade slightly (flatter). Caution: Do not flatten the fan blade completely since this will only destroy the efficiency of the heater.

■ HELPFUL MAINTENANCE HINTS

READ CAREFULLY BECAUSE THEY CAN SAVE YOU TIME AND MONEY!

1. Jars should fit freely and stand upright in turntable. If they don't, turn jars in opening to compensate for the unevenness. Jars are not always uniformly round.
2. If the jar lids don't rest properly on the jars in the stopped position, turn jars in opening to compensate for the unevenness. If the height between the lid and the jar is too great, see "Adjustment Basket Height" Section.
3. Do not install side baffles in jars—they are not necessary.
4. If machine has stalled accidentally and does not continue to function, you can remedy this by lightly bouncing the outer column on the inner column or by removing the outer column assembly and lightly tugging the inner column piston upwards. The machine will then resume operations.
5. If the machine does not stop at the end of the cleaning cycle, this indicates that the control switches are not functioning. The top switch D of the geneva stack and bottom switch C of the escapement stack control the stopping of the machine. See "Switch Adjustment" Section for instructions.
6. Do not allow anything to hold the turntable while turning.
7. It is advisable to run the machine through the cleaning cycle without baskets every morning in order to assure proper fluid flow and to "warm up" the machine. **THIS IS IMPORTANT.**
8. Make sure that the fanwheel clears the jars at the proper height—the outer column must clear the scribe mark on the inner column.
9. Keep jars clean! When changing solutions, jars should be washed and thoroughly dried with a *lint-free* cloth. Jar tops should be wiped off occasionally.
10. Give your machine a thorough checking at least twice a year. Tighten all screws and fittings, clean the mechanisms inside.
11. It is desirable to keep the machine in a clean location. Avoid spilling solutions on machine.
12. In the event your machine does not function properly after you have tried to remedy the fault, please contact us immediately. Supply us with the machine's serial number. *Do not return your machine without first receiving shipping instructions from us!*

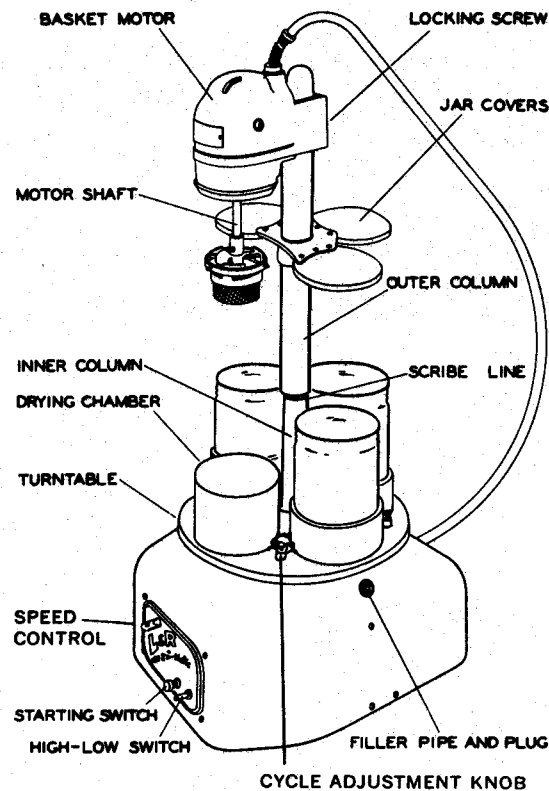

Machine Diagram and Parts List

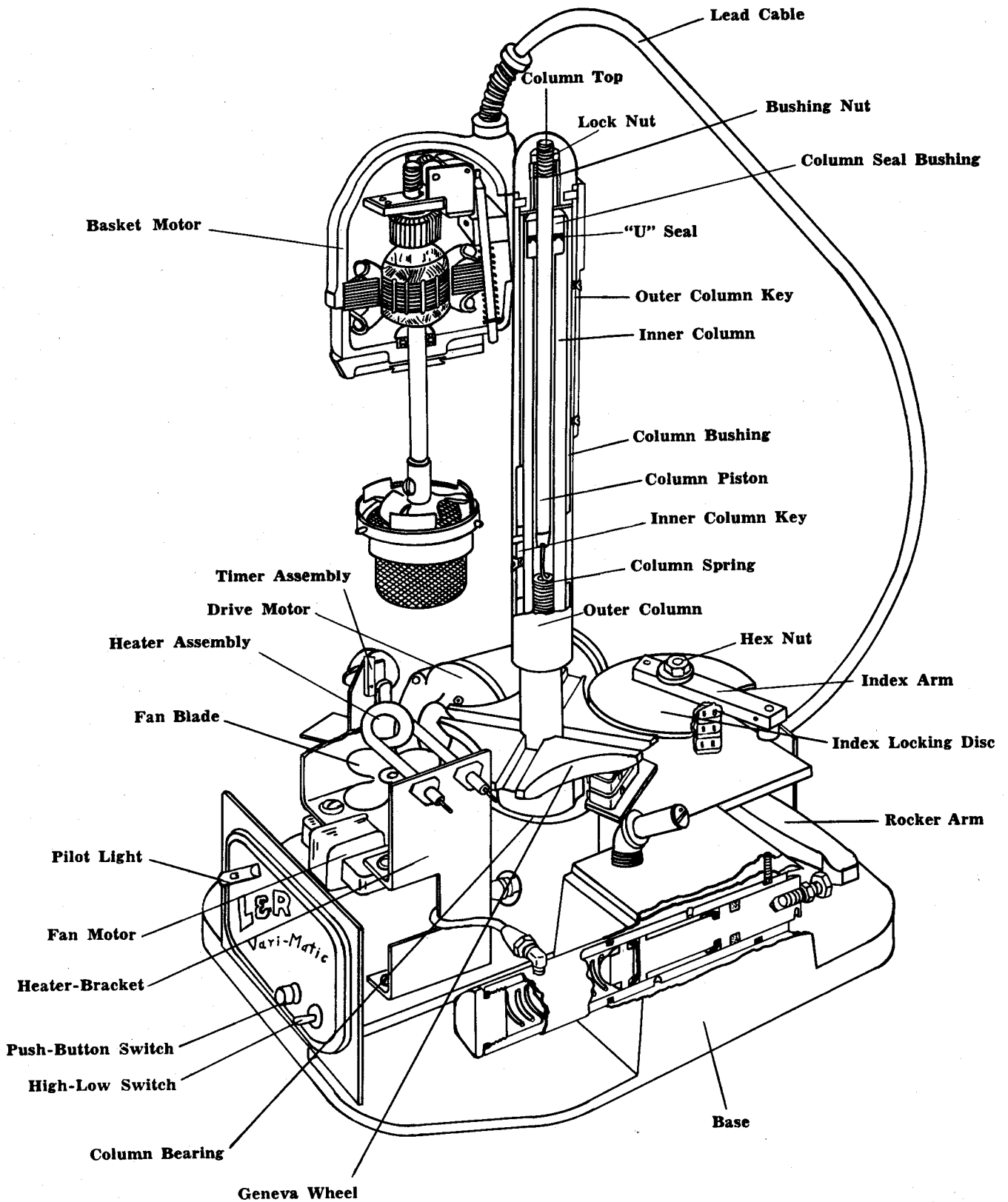

Wiring Diagram

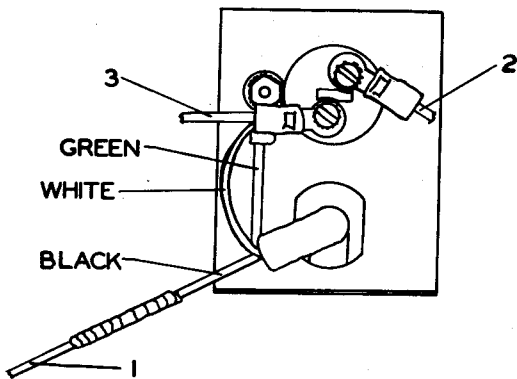
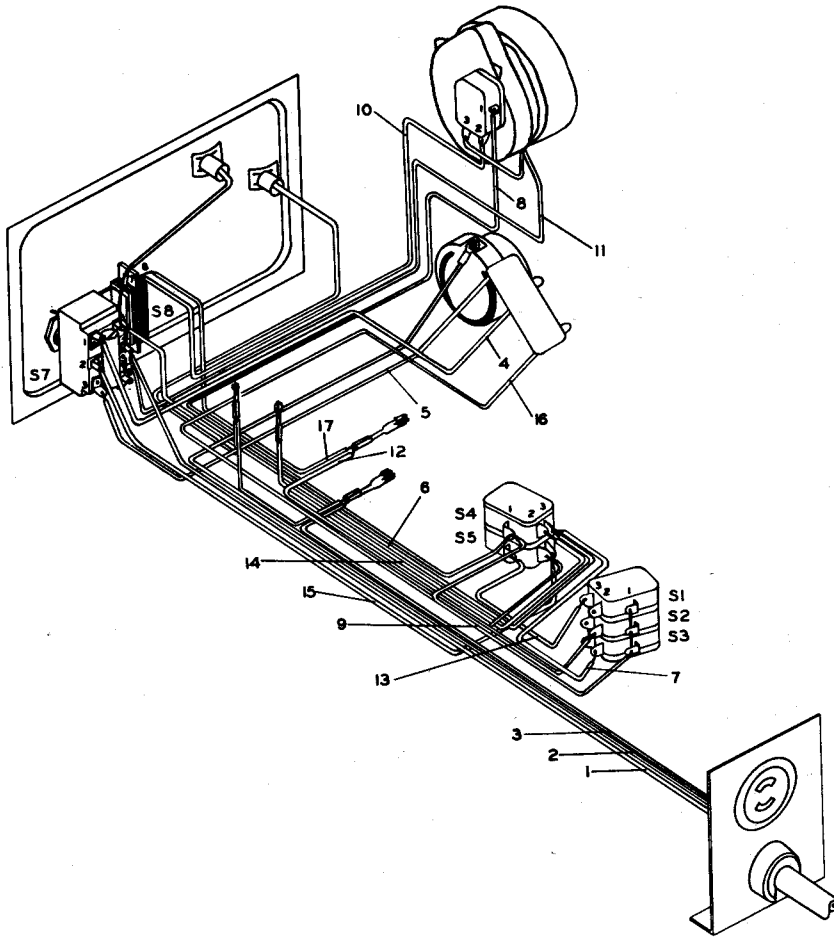
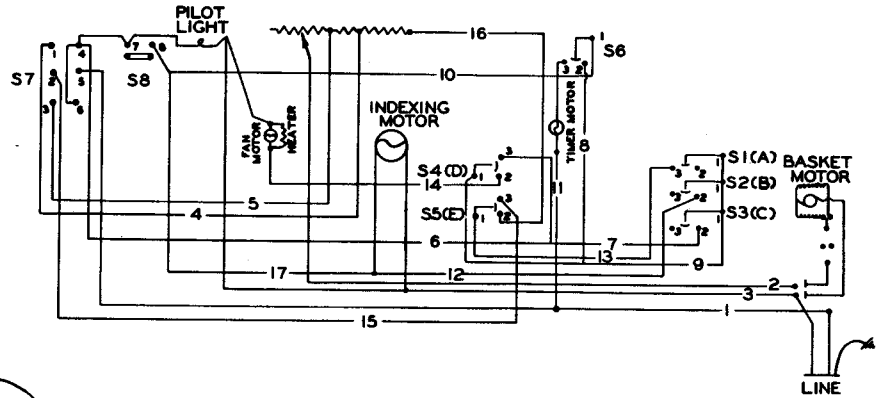

DET.	REQ.	WIRE	LENGTH
16	1	ORANGE	17"
15	1	GREY	12"
14	1	TAN	14"
13	1	PINK	5"
12	1	BROWN	9½"
11	1	BROWN	.6"
10	1	YELLOW	14¾"
9	1	YELLOW	5½"
8	1	BLUE	8¾"
7	1	PURPLE	5"
6	1	PURPLE	12½"
5	1	PURPLE	8½"
4	1	PURPLE	11"
3	2	RED	11¾"
2	1	BLACK	19⅝"
1	1	GREEN	16"

Hydraulic System

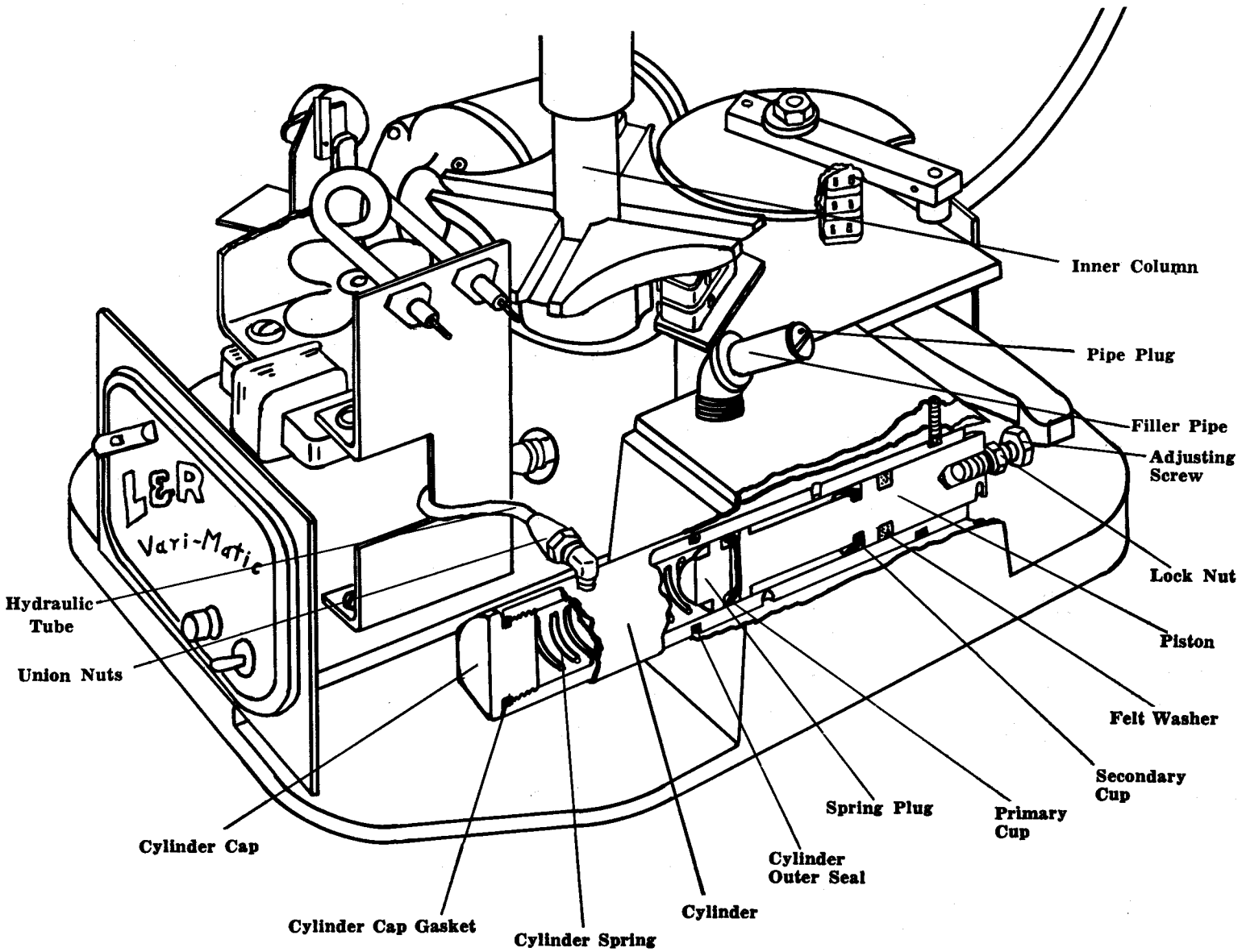

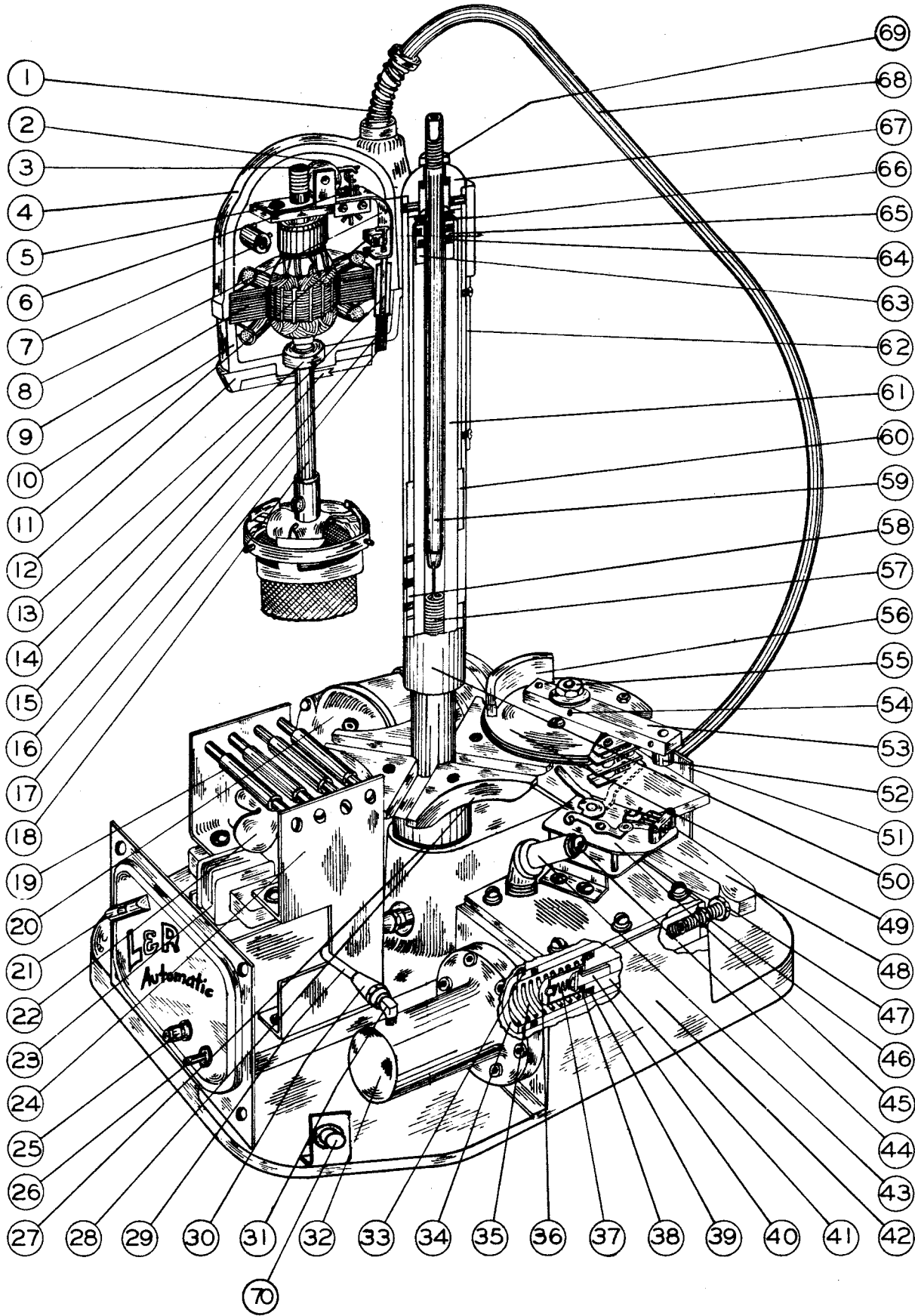

PARTS LIST

1	Strain Relief	24	Bracket-Heater	47	Screw-Adjusting
2	Eccentric	25	Switch-Push Button	48	Arm-Rocker
3	Worm Gear	26	Switch-Center Off	49	Disc-Index Locking
4	Hanger	27	Bearing-Column	50	Column-Outer
5	Adjustment Screw	28	Wheel-Geneva	51	Bracket-Cable
6	Switch-Reversing	29	Tube-Hydraulic	52	Stud-Index
7	Resistor	30	Nut-Union	53	Arm-Index
8	Switch Bracket	31	Elbow	55	Nut-Hex
9	Field Assembly	32	Head-Cylinder	56	Cam-Latch
10	Case	33	Ring-Cylinder	57	Spring-Column
11	Control Switch	34	Cylinder-Hydraulic	58	Key-Inner Column
12	Seal Top	35	Spring-Cylinder	59	Piston-Column
13	Ball Bearing	36	Cage-Valve	60	Bushing-Column
14	Pin-Actuator	37	Spring-Valve	61	Column-Inner
15	Slinger	38	"O" Ring-Valve	62	Key-Outer Column
16	Screws-Actuator	39	"O" Ring-Piston	63	Washer-Column Seal
17	Actuator	40	Valve	64	"O" Ring-Piston
18	Armature Assembly	41	Piston	65	Column Seal Bushing
19	Heater Assembly	42	Base	66	National Ring
20	Motor-Drive	43	Pipe-Filler	67	Top-Column
21	Light-Pilot	44	Plug-Filler	68	Lead Cable
22	Blade-Fan	45	Timer	69	Nut-Knurled Locking
23	Motor-Fan	46	Nut-Lock	70	Switch-Indexing